

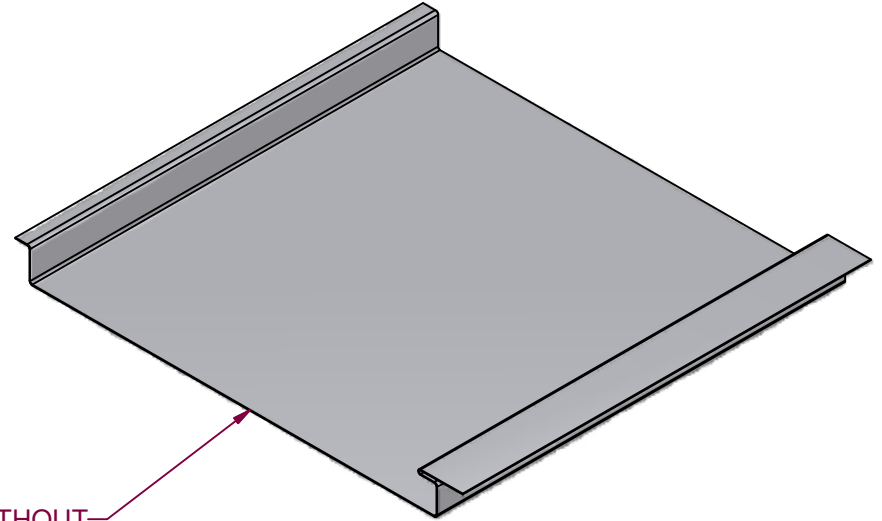

**NOTE:**  
MATERIAL USAGE: 4"

WHEN USING PERFORATOR:  
MAXIMUM NET FREE AREA = 2.65 SQUARE INCHES  
PER 12 INCHES OF PERFORATION  
MAXIMUM OF TWO PERFORATIONS PER PANEL.

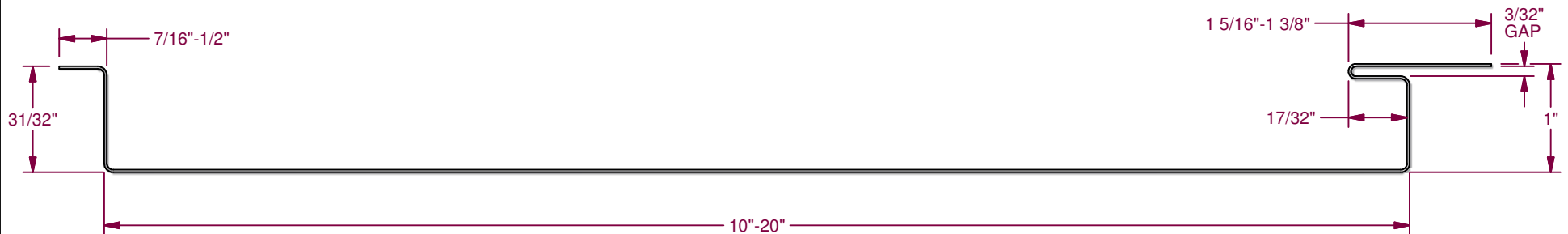

PANEL SHOWN WITHOUT PERFORATIONS.



MATERIAL				FINISH		 <b>NEW TECH MACHINERY CORP.</b>		<b>FWM PANEL PROFILE</b>		
REVISION HISTORY	REV	ECR NO.	DATE	RELEASED BY	TOLERANCES .XX = ± .01 .XXX = ± .005 FRACTION = ± 1/32" ANGLE = ± 1/2'					DRAWN BY JD
						DATE 11/28/07				
							CHECK BY FRY			
							DATE 11/29/07			